

Ansicht 1 / 3D

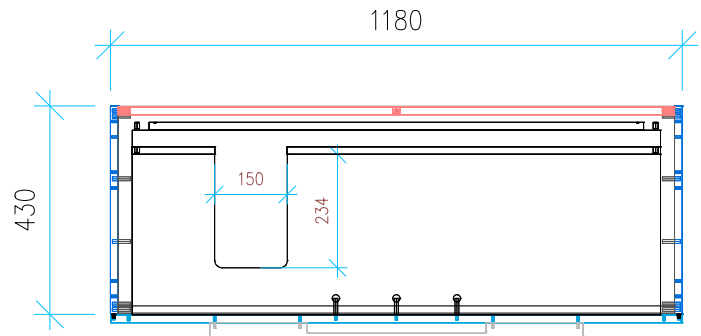

Ansicht 2 / Draufsicht

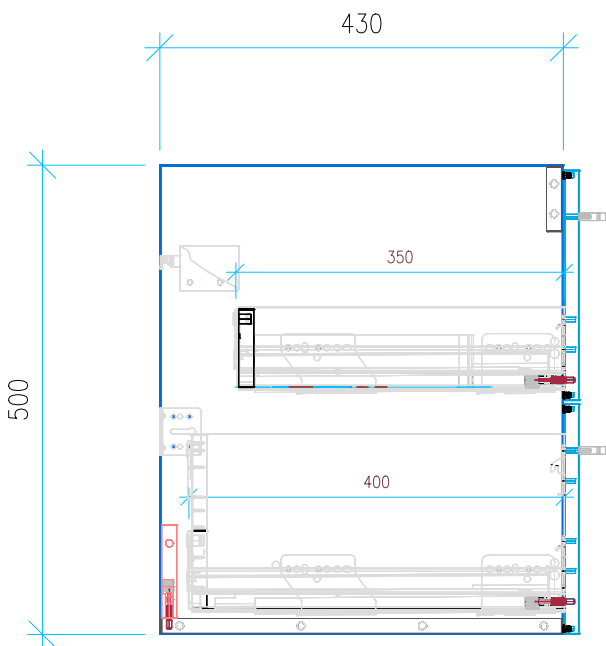

Ansicht 3 / Seitenansicht Links

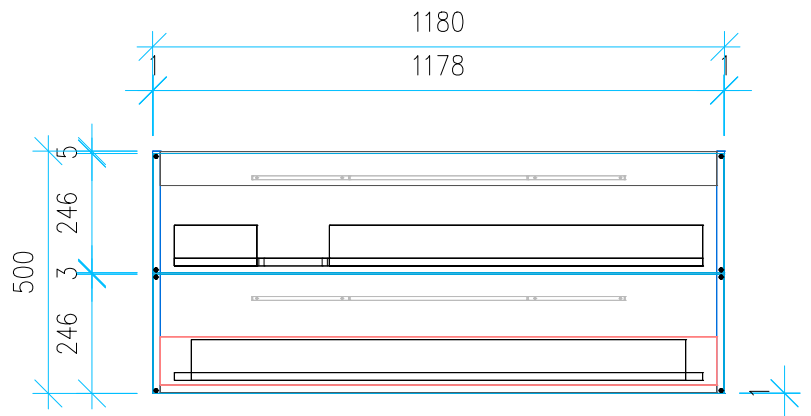

Ansicht 4 / Vorderansicht

Höhe <b>500</b>	Erstellt <b>15.07.2022</b>	Artikelname
Breite <b>1180</b>	Maße in mm	<b>WTU_LAUF_KARTELL_120L_SC</b>
Tiefe <b>430</b>	Gewicht in kg	
Gewicht <b>33.221</b>		